

Technical sheet :

MXT 840 K



Capacities		Metric
Max. capacity		4000 kg
Max. lifting height		7.60 m
Max. outreach		4.23 m
Weight and dimensions		
Overall length to carriage	l11	4.67 m
Overall width	b1	2.38 m
Overall height	h17	2.59 m
Wheelbase	y	2.58 m
Ground clearance	m4	0.37 m
Overall cab width	b4	0.85 m
Tilt-up angle	a4	12 °
Tilt-down angle	a5	114 °
External turning radius (over tyres)	Wa1	3.90 m
Unladen weight (with forks)		8420 kg
Unladen weight		8060 kg
Tyres type		Inflatable
Standard tyres		BKT 16.0/70-20 14PR- EM936 SPL
Forks length / width / section	l / e / s	1200 mm x 125 mm / 45 mm
Performances		
Lifting		13 s
Lowering		9 s
Extension		9 s
Retraction		5 s
Scoop		4.60 s
Dump		3.90 s
Engine		
Engine brand		Kirloskar
Engine norm		BS-IV CEV
Max. fuel sulphur content		300 ppm
Engine model		4R1190NA1
Number of cylinders / Capacity of cylinders		4 - 4760 cm ³
I.C. Engine power rating - Power (kW)		74.50 Hp / 54.80 kW
Max. torque / Engine rotation		300 Nm @ 1320 rpm
Drawbar pull (Laden)		8300 daN
Transmission		
Transmission type		Torque converter
Number of gears (forward / reverse)		4 / 4
Max. travel speed		28 km/h
Parking brake		Oil-Immersed Multi-Disc Braking front and rear Axle
Service brake		Hydraulic rear & front
Hydraulics		
Hydraulic pump type		Gear pump
Hydraulic flow / Pressure		92 l/min / 250 bar
Tank capacities		
Engine oil		9.50 l
Hydraulic oil		120 l
Fuel tank		78.50 l
Noise and vibration		
Noise at driving position (LpA)		90 dB
Noise to environment (LwA)		110 dB
Vibration on hands/arms		< 2.50 m/s ²
Miscellaneous		
Steering wheels (front / rear)		2 / 2
Drive wheels (front / rear)		2 / 2
Safety cab homologation		Cabin ROPS - FOPS Level 2
Controls		Monolever

MXT 840 K - Dimensional drawing

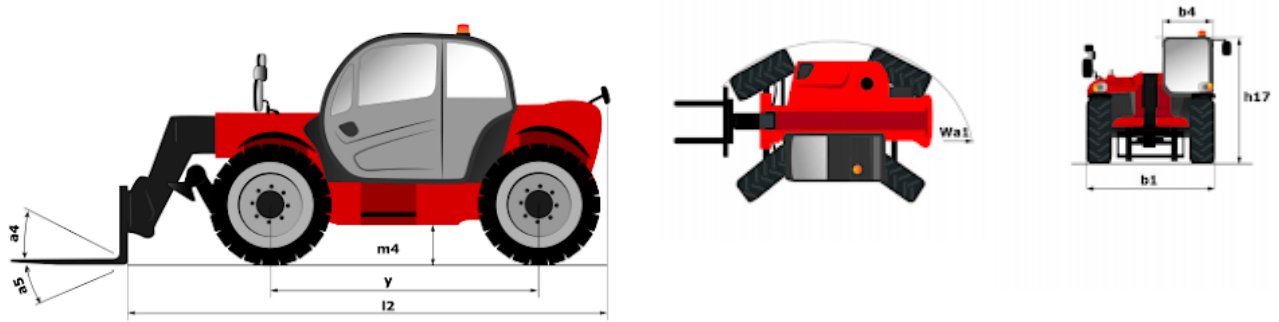

MXT 840 K - Load chart

Machine on tyres with forks Metric

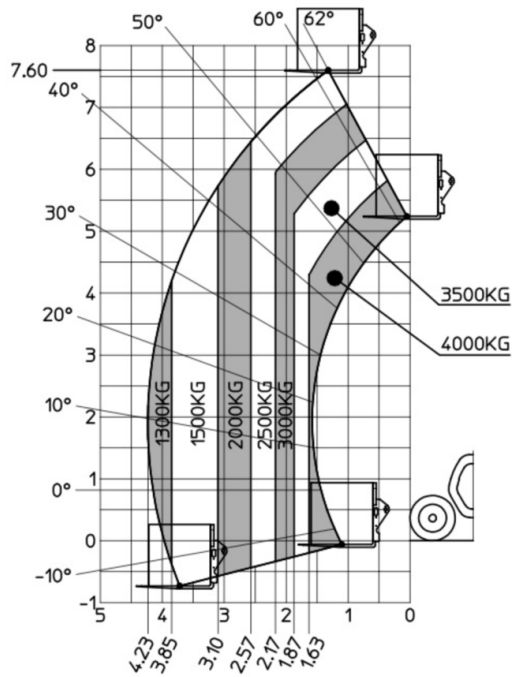



Siège Social

430 rue de l'Aubinière - 44150 Ancenis Cedex - France

Tel: +33(0)2 40 09 10 11 - Fax: +33 (0)2 40 09 10 97

www.manitou.com



This brochure describes versions and configuration options for Manitou products which may be fitted with different equipment. The equipment described in this brochure may be standard, optional or not available depending on version. Manitou reserves the right to change the specifications shown and described at any time and without prior warning. The manufacturer is not liable for the specifications given. For more information, contact your Manitou dealer. Non-contractual document. Product descriptions may differ from actual products. List of specifications is not comprehensive. The logos and visual identity of the company are the property of Manitou and may not be used without authorisation. All rights reserved. The photos and diagrams contained in this brochure are provided for information only.

MANITOU BF SA - Limited company with board of directors - Share capital: 39,668,399 euros - 857 802 508 RCS Nantes